

# D-3E User Guide

## D/A CONVERTER

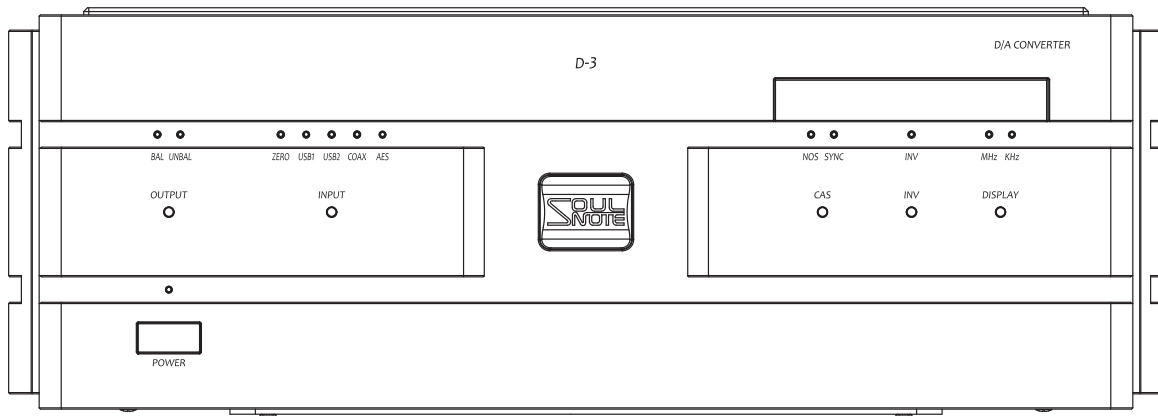

## Table of Contents

Safety Precautions.....	3
Front Panel Names and Functions .....	6
Rear Panel Names and Functions.....	8
Remote Control Button Names and Functions .....	10
Remote Control.....	11
Features of This Product .....	12
About ZERO LINK .....	14
USB Connection with a Computer .....	16
DISPLAY button.....	17
Power Cable Connection .....	17
Balanced Input/Output.....	17
Attaching the Spike Pins.....	17
Protection Pads for Transport.....	18
Troubleshooting .....	18
Maintenance .....	18
Specifications.....	19

### Supplied Accessories

• User Guide (this manual) .....	1	• Hex key for spike pins .....	1
• Power cable .....	2	• Wrench for the SMA cable.....	1
• Spike-receiving board .....	1	• Remote control .....	1
• Spike pin .....	3		

## Safety Precautions



### CAUTION

RISK OF ELECTRIC SHOCK  
DO NOT OPEN



CAUTION: TO REDUCE THE RISK OF ELECTRIC SHOCK, DO NOT REMOVE COVER (OR BACK). NO USER-SERVICEABLE PARTS INSIDE. REFER SERVICING TO QUALIFIED SERVICE PERSONNEL.



The lightning flash with arrowhead symbol, within an equilateral triangle, is intended to alert the user to the presence of uninsulated “dangerous voltage” within the product’s enclosure that may be of sufficient magnitude to constitute a risk of electric shock to persons.



The exclamation point within an equilateral triangle is intended to alert the user to the presence of important operating and maintenance (servicing) instructions in the literature accompanying the product.

### WARNING

TO REDUCE THE RISK OF FIRE OR ELECTRIC SHOCK, DO NOT EXPOSE THIS APPLIANCE TO RAIN OR MOISTURE.

A warning that an apparatus with CLASS I construction shall be connected to a MAINS socket outlet with a protective earthing connection.

# IMPORTANT SAFETY INSTRUCTIONS

## READ BEFORE OPERATING EQUIPMENT

This product was designed and manufactured to meet strict quality and safety standards. There are, however, some installation and operation precautions which you should be particularly aware of.

1. Read these instructions.
2. Keep these instructions.
3. Heed all warnings.
4. Follow all instructions.
5. Do not use this apparatus near water.
6. Clean only with dry cloth.
7. Do not block any ventilation openings.  
Install in accordance with the manufacturer's instructions.
8. Do not install near any heat sources such as radiators, heat registers, stoves, or other apparatus (including amplifiers) that produce heat.
9. Protect the power cord from being walked on or pinched particularly at plugs, convenience receptacles, and the point where they exit from the apparatus.
10. Only use attachments/accessories specified by the manufacturer.
11. Use only with the cart, stand, tripod, bracket, or table specified by the manufacturer, or sold with the apparatus. When a cart is used, use caution when moving the cart/apparatus combination to avoid injury from tip-over.
12. Unplug this apparatus during lightning storms or when unused for long periods of time.
13. Refer all servicing to qualified service personnel. Servicing is required when the apparatus has been damaged in any way, such as power-supply cord or plug is damaged, liquid has been spilled or objects have fallen into the apparatus, the apparatus has been exposed to rain or moisture, does not operate normally, or has been dropped.
14. Batteries shall not be exposed to excessive heat such as sunshine, fire or the like.



### CAUTION:

- To completely disconnect this product from the mains, disconnect the plug from the wall socket outlet. The mains plug is used to completely interrupt the power supply to the unit and must be within easy access by the user.
- Never use the unit with any other cord except the supplied power cord.

### NOTE ON USE

#### WARNINGS

- Avoid high temperatures.  
Allow for sufficient heat dispersion when installed in a rack.
- Handle the power cord carefully.  
Hold the plug when unplugging the cord.
- Keep the unit free from moisture, water, and dust.
- Unplug the power cord when not using the unit for long periods of time.
- Do not obstruct the ventilation holes.
- Do not let foreign objects into the unit.
- Do not let insecticides, benzene, and thinner come in contact with the unit.
- Never disassemble or modify the unit in any way.
- Ventilation should not be impeded by covering the ventilation openings with items, such as newspapers, tablecloths or curtains.
- Naked flame sources such as lighted candles should not be placed on the unit.
- Observe and follow local regulations regarding battery disposal.
- Do not expose the unit to dripping or splashing fluids.
- Do not place objects filled with liquids, such as vases, on the unit.
- Do not handle the mains cord with wet hands.
- When the switch is in the OFF position, the equipment is not completely switched off from MAINS.
- The equipment shall be installed near the power supply so that the power supply is easily accessible.

### DECLARATION OF CONFORMITY

We declare under our sole responsibility that this product, to which this declaration relates, is in conformity with the following standards:

EN60065, EN55032, EN55020.

Following the provisions of Low Voltage Directive 2014/35/EU and EMC Directive 2014/30/EU.

### A NOTE ABOUT RECYCLING:

This product's packaging materials are recyclable and can be reused. Please dispose of any materials in accordance with the local recycling regulations. When discarding the unit, comply with local rules or regulations.

Batteries should never be thrown away or incinerated but disposed of in accordance with the local regulations concerning battery disposal. This product and the supplied accessories, excluding the batteries, constitute the applicable product according to the WEEE directive.



Pb

### CAUTIONS ON INSTALLATION

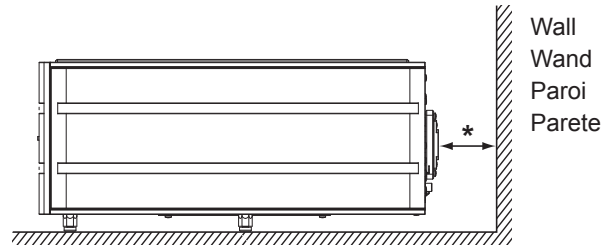
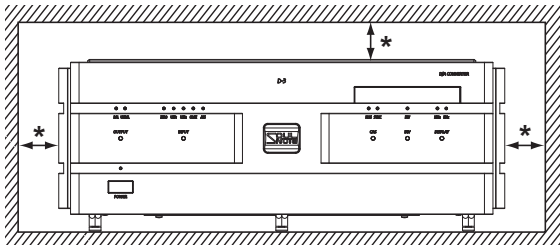

**\* For proper heat dispersal, do not install this unit in a confined space, such as a bookcase or similar enclosure.**

- Leave sufficient clearance (at least 10 cm) from the wall, (at least 5 cm) from top surface of the unit.
- Do not place any other equipment on this unit.

# Front Panel Names and Functions

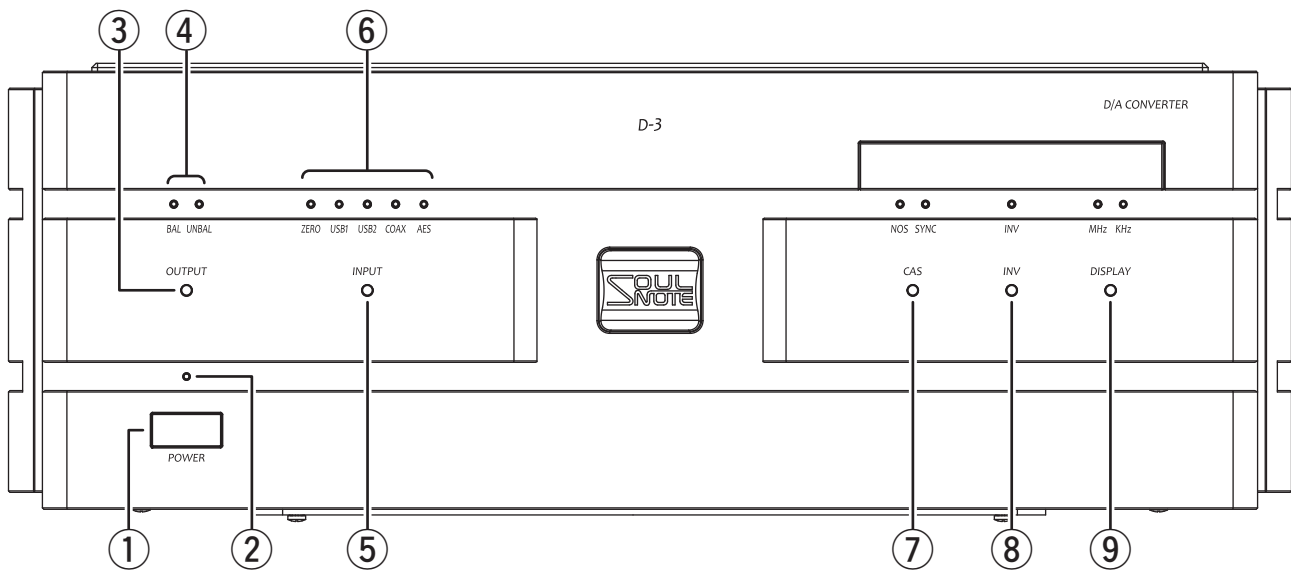

## ① Power Switch (POWER)

Press to turn on the power, and press again to turn off.

### Note:

- When an external clock is not connected, the power cannot be turned on. (All indicators except the power indicator do not turn on.)

## ② Power Indicator

When the power is on, the indicator is lit blue.

## ③ Output Selection Switch (OUTPUT)

Pressing the switch toggles between balanced output and unbalanced output.

### Note:

- Balanced output and unbalanced output cannot be performed simultaneously.

## ④ Output Indicators

The selected output is lit.

### Note:

- BAL (balanced) is lit blue and UNBAL (unbalanced) is lit red.

## ⑤ Input Selection Switch (INPUT)

An input source can be selected. Each time the switch is pressed, the input source changes: ZERO → USB1 → USB2 → COAX → AES → ZERO ....

## ⑥ Input Source Indicators

The input source currently selected is lit.

### Note:

- Only ZERO LINK is lit blue whereas others are lit red.

## ⑦ Playback Mode Selection Switch (CAS) (CAS: Calculation Algorithm Select)

Pressing the switch toggles between NOS (Non Oversampling) and FIR (8x Oversampling Digital Filter). Each time the switch is pressed, the playback mode toggles NOS → FIR → NOS.

### Notes:

- In NOS mode, the NOS indicator is lit green.
- To obtain better audio quality, using NOS is recommended.
- NOS is not available for DSD.
- PCM is fixed to NOS for USB input.

## ⑧ Invert Switch (INV)

Pressing the switch inverts the balanced output phase. Pressing again reverts to the original phase.

### Notes:

- This product uses Pin 2 hot for balanced output. If you use a preamplifier or pre-main amplifier with Pin 3 hot, invert the phase. Also, when the audio source phase is inverted, use this switch.
- Unbalanced output is not inverted.

## ⑨ Display Off Switch (DISPLAY)

Pressing the switch turns off all indicators except for the power indicator. Pressing again reverts to the original state.

### Notes:

- To obtain better audio quality, keeping the display off is recommended.
- While the display is off, pressing any switch causes indicators to turn on only for 4 seconds and then turn off.

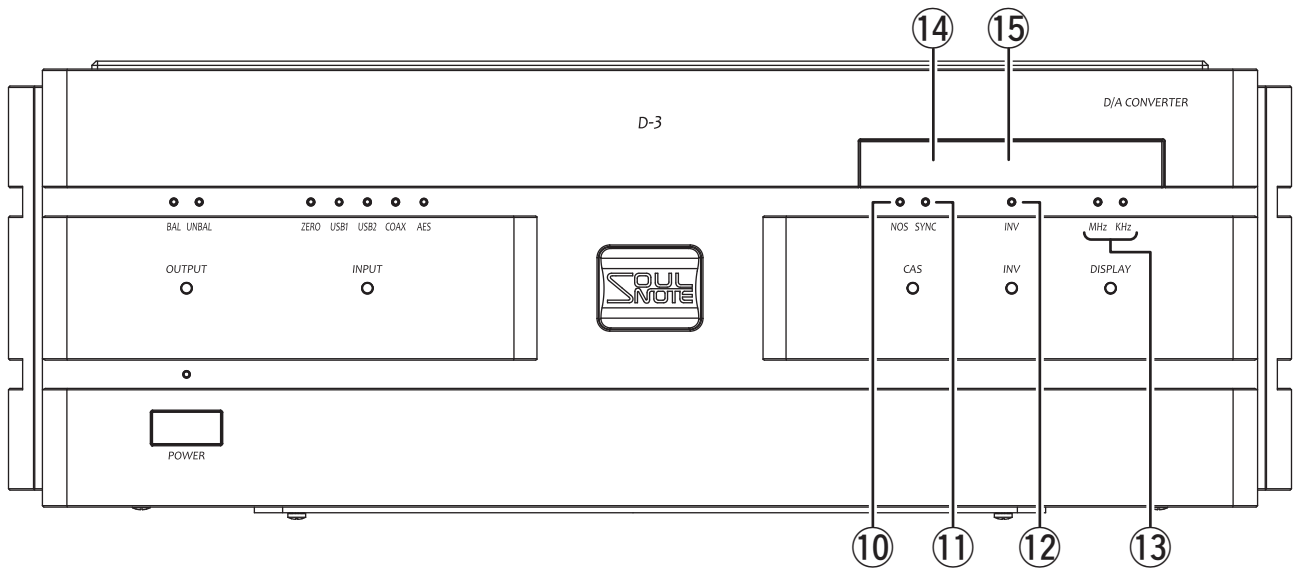

### ⑩ NOS Indicator (NOS)

When in NOS mode, this indicator is lit green.

#### Notes:

- For PCM playback, NOS is recommended to obtain better audio quality.
- When using the FIR filter (8x Oversampling Digital Filter) for PCM playback, this indicator turns off.
- NOS is also SYNC (DPLL-OFF, full sync) but the SYNC indicator does not turn on (blue).
- NOS is not available for DSD.

### ⑪ SYNC Indicator (SYNC)

When in SYNC (DPLL-OFF, full sync) mode, this indicator turns on (blue).

#### Note:

- SYNC is automatically enabled during DSD playback.

### ⑫ Invert Indicator

When the phase is inverted, this indicator turns on (yellow).

### ⑬ Sampling Frequency Unit Indicators

Indicates the sampling frequency unit. (MHz/KHz)

### ⑭ Remote Control Receiver

Receives infrared signals from the remote control.

#### Note:

- Point the remote control at the remote control receiver.

### ⑮ Sampling Frequency Display

Displays the sampling frequency for the audio source currently being played back.

#### Note:

- During COAX or AES/EBU input, the sampling frequency is not displayed in order to maintain the audio quality.

# Rear Panel Names and Functions

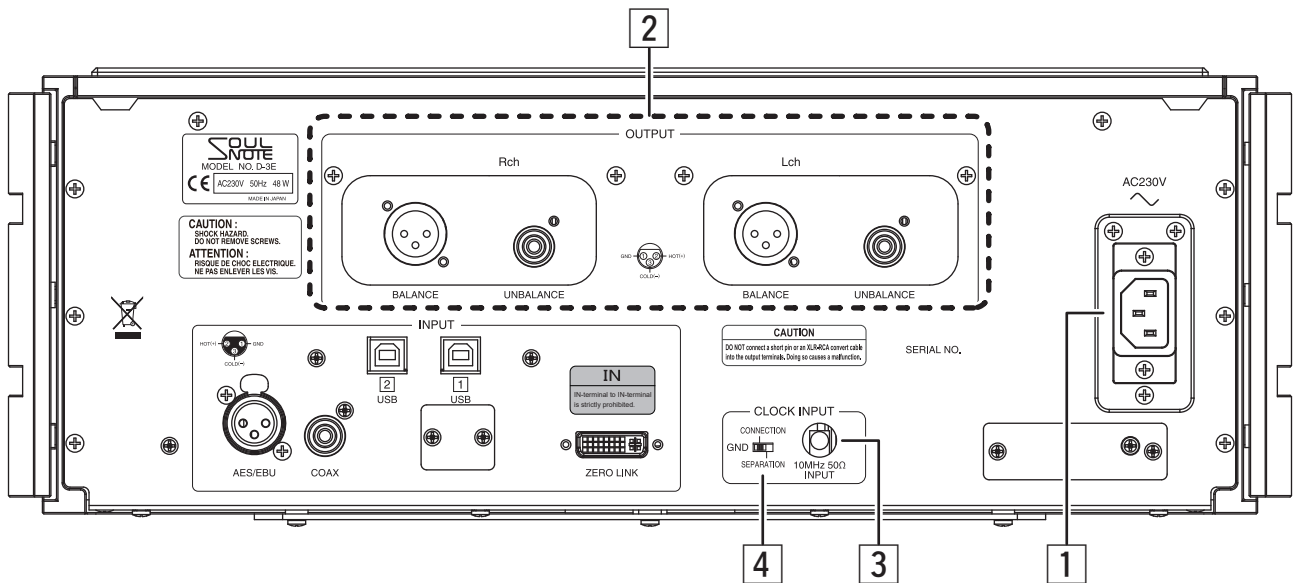

## 1 AC Inlet (AC230V)

Connect to a 230 V AC wall outlet (mains) with the supplied power cable.

### Notes:

- **Do not use any electrical contact cleaner or the like in the AC inlet area.**
- To maintain the audio quality, use the supplied power cable.
- Connect the power cable to the AC wall outlet (mains) by inserting the power plug prong with the engraved OO symbols into the ground side (the longer hole). If you reverse the orientation of the power plug, you cannot fully enjoy the performance of the unit.
- Firmly insert the power cable into the end of the AC inlet.
- The ground terminal and the housing are not connected.

## 2 Audio Output Terminals (OUTPUT)

These terminals output analog sound.

### Notes:

- Only balanced output or unbalanced output that is selected with the output selection switch (OUTPUT) is performed. Balanced output and unbalanced output cannot be performed simultaneously.
- Before connecting cables, turn off the power.
- This product uses Pin 2 hot for balanced output. When connecting to a device with Pin 3 hot, invert the phase with the invert switch (INV).

## 3 10 MHz External Clock Input Terminal (10MHz 50Ω INPUT)

Connect to a 10 MHz clock such as our product, X-3E. Since this is an SMA jack, use a BNC female - SMA male conversion adapter (sold separately) when a general BNC cable is used.

### Notes:

- When connecting an external clock to this product, turn off the power of this product.
- When connecting an SMA cable, plug the cable straight into the terminal. (Otherwise, the screw cannot be turned easily.)
- First, turn the screw with your fingers as far as it will go.
- Then, use the supplied wrench to lightly tighten the screw to the point where it cannot be turned easily.
- **Do not overtighten the screw.**

## 4 External Clock GND Switch (GND)

Select whether to separate the GND of the connected external clock from the D-3E chassis (SEPARATION) or to connect (CONNECTION) the GND.

### Note:

- Selecting CONNECTION is recommended to obtain better audio quality.



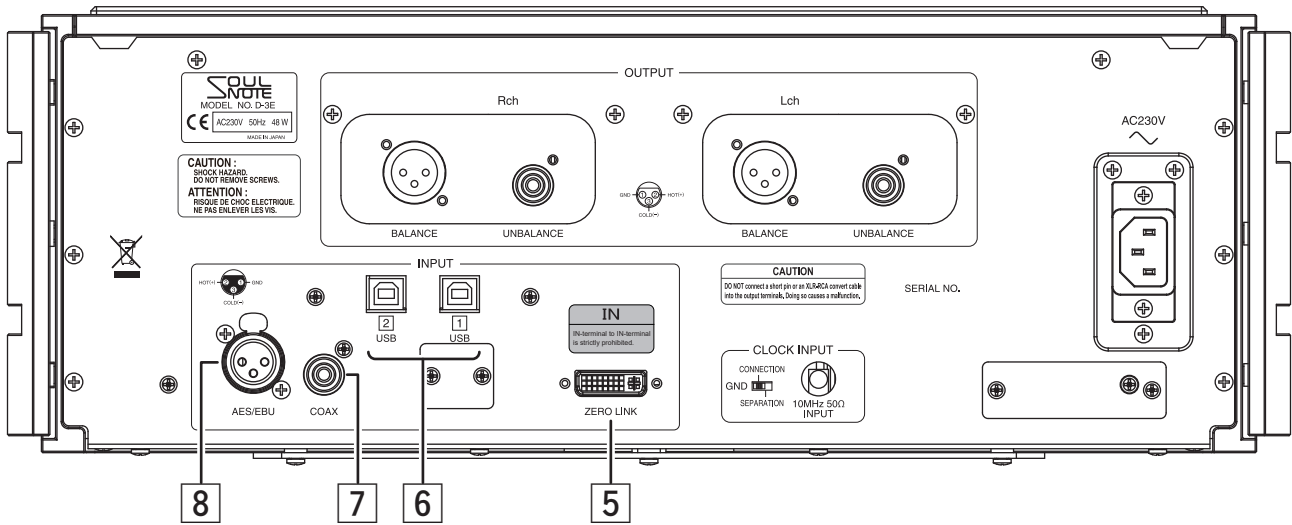

## 5 ZERO LINK Input Terminal (ZERO LINK)

Connect to a network transport equipped with a ZERO LINK output terminal such as Z-3E using a ZERO LINK designated cable. This input terminal provides the highest audio quality but a special attention is required for when connecting.

### Notes:

- **When connecting a ZERO LINK designated cable to devices, turn off the power of the devices to be connected together.** Connecting/Disconnecting the cable while the power of the devices is on can cause the devices to become faulty. **Also, do not touch the connector (where signals are transmitted) of the ZERO LINK designated cable.** Even when the power of the devices is off, the devices might become faulty due to static static. Be sure to tighten the screws to secure the cable.
- Do not connect input terminals (blue stickers) on both sides, or do not connect output terminals (yellow stickers) on both sides of the cable. It will cause a malfunction.
- Do not connect a computer monitor or the like to the terminal. It will cause a malfunction.

## 6 USB Input Terminals (USB1/USB2)

Connect to devices such as a music server, network transport, and computer with a USB cable. For details, see “USB Connection with a Computer” (page 16) or CSR, Inc. website.

### Note:

- To connect to a Windows computer, a designated driver is required. The driver can be downloaded from CSR, Inc. website.

## 7 COAX Input Terminal (COAX)

Connect to an external device equipped with an S/PDIF format applicable digital output terminal with a 75-ohm coaxial digital cable.

## 8 AES/EBU Input Terminal (AES/EBU)

Connect to a device with an AES/EBU digital output terminal with an XLR digital cable.

# Remote Control Button Names and Functions

The grayed out portions are not available on this device.

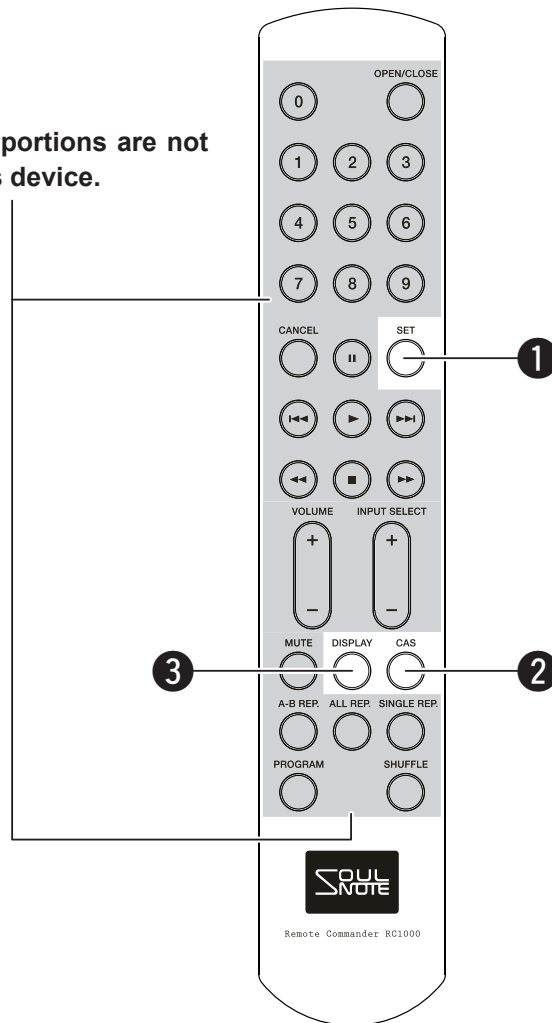

## 1 SET Button

It functions in the same manner as the input selection switch (INPUT) on the unit.

Each time the button is pressed, the input source changes: ZERO → USB1 → USB2 → COAX → AES → ZERO ....

## 2 CAS Button

It functions in the same manner as the CAS switch on the unit.

Each time the button is pressed, the playback mode toggles NOS → FIR → NOS.

### Notes:

- In NOS mode, the NOS indicator is lit green.
- To obtain better audio quality, using NOS is recommended.
- NOS is not available for DSD.
- PCM is fixed to NOS for USB input.

## 3 DISPLAY button

It functions in the same manner as the display off switch (DISPLAY) on the unit.

Pressing the button turns off all indicators except for the power indicator. Pressing again reverts to the original state.

### Notes:

- To obtain better audio quality, keeping the display off is recommended.
- While the display is off, pressing any switch causes indicators to turn on only for 4 seconds and then turn off.

# Remote Control

## ■ Notes on Operation

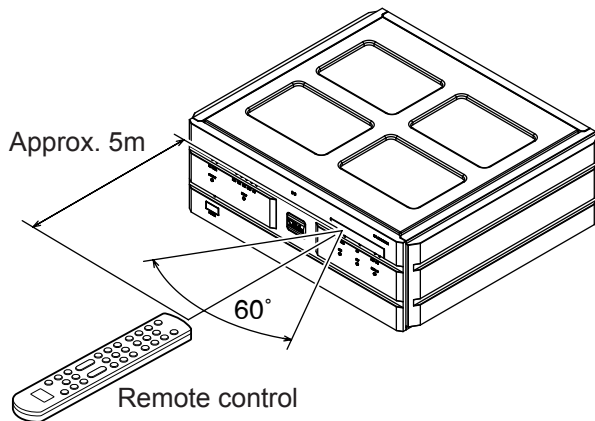

Operate the remote control within approx. 5 m distance from the front panel of the main unit within an angle of 60° to the remote sensor.

- Prevent the remote sensor from being exposed to strong light.
- Do not place any obstacles between the remote control and the remote sensor.
- Do not use other remote controls while using the remote control for the main unit.

## ■ How to Change the Batteries

Remove the lid on the rear side of the remote control and insert 2 AAA (LR03/R03) batteries as indicated inside the battery compartment. After inserting the batteries, attach the cover again.

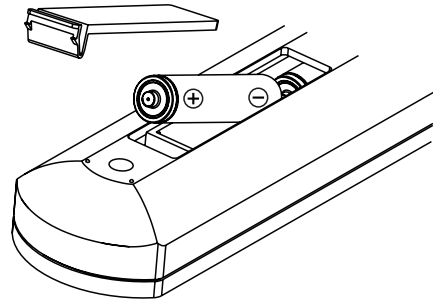

## Cautions on Batteries

- Use AAA (LR03/R03) batteries for the remote control.
- Replace the remote control batteries with new ones after approx. 1 year has passed.
- If you cannot operate the main unit by using the remote control at a short distance from the main unit, change the batteries with new ones even if 1 year has not yet passed.
- Insert batteries with the correct polarity as indicated by the “+” and “-” symbols inside the battery compartment.
- Do not use old and new batteries at the same time. Doing so may cause battery leakage or rupture. Furthermore, do not use different types of batteries together.
- Do not short-circuit, disassemble, or heat batteries. Do not throw batteries into a fire.
- When not using the remote control for a long period of time, remove the batteries.
- If battery leakage occurs, wipe the battery liquid from the battery compartment and then insert new batteries.
- When disposing of batteries, follow appropriate local guidelines and regulations such as ordinances.

## Features of This Product

### **Feature 1: ZERO LINK**

---

ZERO LINK is a standard formulated by SFORZATO and SOULNOTE. It is an ultimate link for achieving higher audio quality by eliminating asynchronous circuits from the D/A converter. Connecting to a network transport equipped with ZERO LINK enables you to build a network system that is fully synchronized by the clock on the DAC side, and eliminating asynchronous circuits dramatically improves the audio quality. The layout is designed specifically for ZERO LINK. Input signals from the ZERO LINK terminal are transmitted to the DAC chip connected in a straight line through the selector constituted by mechanical relays without jitter load.

### **Feature 2: Twin Monaural Construction for the Analog Parts**

---

This product employs twin monaural construction where exactly the same output terminals, Type-R circuits, power circuits, power transformers, relay drive circuits, and relay powers are used for right and left channels. Also, the digital power supply including the transformer is completely isolated. Furthermore, control signals of relays which are contact points with analog signals are completely isolated by use of an analog photo-coupler. In addition, the entire board mounting aluminum base is unsecured producing open and emotional sound. The analog circuit board is mounted on multiple board chassis. The right and left board chassis are separated. It is also separated from the rear panel. In the same manner as our product P-3E, the right and left GND are grounded on the right-and-left independent side aluminum ground anchors, which are isolated from the chassis by use of foam teflon cables.

### **Feature 3: Type-R Circuit Employed for the Non-feedback Balanced Amplifier**

---

The output line amplifier is equipped with a "Type-R circuit" which is a discrete non-feedback balanced circuit of the same grade as our product P-3E. Furthermore, the newly developed ultra-high precision naked foil resistance is incorporated into the design. With the emitter resistance of 1 ohm and output resistance of 3.9 ohms, this product dramatically improves the amount of information and S/N, and boosts the drive performance to the power-amplifier level.

### **Feature 4: Used 4 Units of ES9038PRO**

---

For the DAC chip, 2 units of ES9038PRO are used for each channel (4 in total). The unparalleled strong current output, 120 mA per channel, is indispensable for the discrete non-feedback DAC.

This current output is converted into voltage just before the first stage of the Type-R circuit with an IV resistance owing to the naked foil resistance.

### **Feature 5: Designed Specially for Using an External Clock**

---

For clocks which greatly affect audio quality of D/A converters, we discovered that separating the clock from the unit is better than installing it in the unit to maintain the audio quality. By having the clock in a different housing with a different power supply, time can be kept quietly. For this reason, we do not use a built-in clock anymore. The unit is designed specially for use with an external clock. For an external clock, the most ideal product is our X-3E to maintain the audio quality. For the clock cable, using RCC-1 is highly recommended.

### **Feature 6: Femto Level DDS**

---

With the ultra-low jitter DDS of 45 femtoseconds (fs), LMX2594, a high-quality master clock is generated from the input 10 MHz clock according to the sampling frequency. As a result, ES9038PRO can be operated in Non-DPLL mode (128fs mode) with which you can get the best audio quality. During the ZERO LINK operation, the sampling frequency is transmitted by the transport for each audio track and then a master clock is generated according to it. This achieves "full sync with the transport" without use of a PLL or sampling rate converter.

### **Feature 7: Power Transformers with Right-and-left Independently Grounded Construction**

There are 3 power transformers: a digital transformer, right and left analog transformers. They are mounted on the independent side aluminum bases, and vibration of each transformer is output from each base with a spike grounded. Furthermore, the 3 transformers are vertically mounted and the leakage flux is kept parallel to the board, preventing noises from entering patterns. The transformer base which is very important for maintaining the audio quality, has a sandwich structure with aluminum sides that are floated with 3 points by using titanium spacers. The materials, structure, and shape employed for the transformer base are optimal for eliminating resonance while avoiding damping. For commutating capacitors, a total of 152 low-magnification electrolytic capacitors are used. For commutating diodes, a total of 52 ultra-high speed SiC diodes are used. It is a huge cluster of power.

### **Feature 8: Employed NOS Mode**

The highly acclaimed NOS (Non Oversampling) mode is adopted. This mode can prevent pre-eco and post-eco which occur in impulse response of FIR oversampling.

- Impulse output waveform in a FIR oversampling filter

Pre-eco and post-eco are artificial “sound” created by calculation based on the adjacent pieces of data in order to interpolate the data, which makes waveforms such as sine waves smoother in appearance. However, the audio quality changes depending on the calculation algorithm, and ambiguity on the time axis is added.

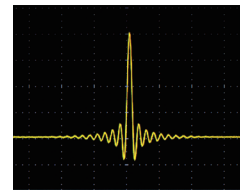

- Impulse output waveform in NOS mode

This is the waveform that can be realized only in combination with a non-feedback discrete amplifier with extremely excellent transient response performance. Since the music waveform is a series of impulse waveforms with different heights, the NOS mode dispels the ambiguity of the time axis information, creating more realistic and natural sound quality as well as a feeling of mood and atmosphere for human hearing which is extremely sensitive with respect to the time axis.



### **Feature 9: RSR-2-12D (Reference SOULNOTE Relay)**

It is based on the ultra-low loss glass tube sealed lead relay whose performance is similar to mercury relay yet is further customized for this unit. The level of the audio quality that our original customized relay realizes is as high as that of wires.

### **Feature 10: Ultra-high Precision Naked Foil Resistance**

It is based on the satellite-grade ultra-high precision foil resistance featuring excellent temperature characteristics yet is further customized for this unit. The naked foil is adopted to eliminate damping and tendencies due to molds and dips.

- For more detailed information, refer to our website or Facebook page.  
[https://www.kcsr.co.jp/eu\\_soulnote.html](https://www.kcsr.co.jp/eu_soulnote.html)

# About ZERO LINK

ZERO LINK is a standard formulated by SFORZATO and SOULNOTE. It is an ultimate link that connects the transport to the D/A converter for achieving higher audio quality by eliminating asynchronous circuits from the D/A converter.

Eliminating asynchronous circuits from the D/A converter dramatically improves the audio quality.

ZERO LINK enables the number of asynchronous circuits in the D/A converter to be “Zero”.

## • Internal operation of common network connections

In all types of connections, there are asynchronous circuits in the D/A converter.

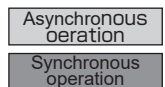

### Structure of a Network Player

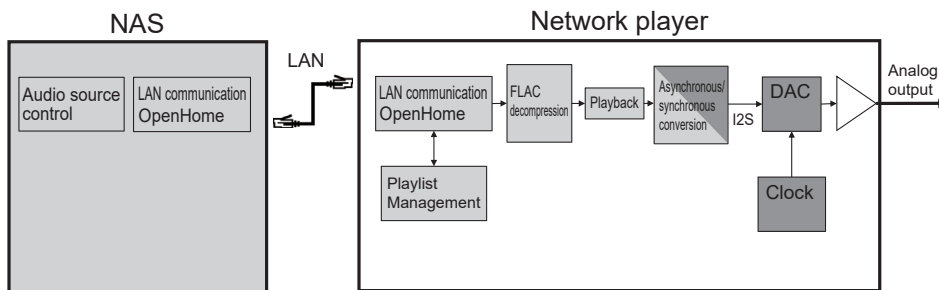

### Structure of a USB D/A Converter

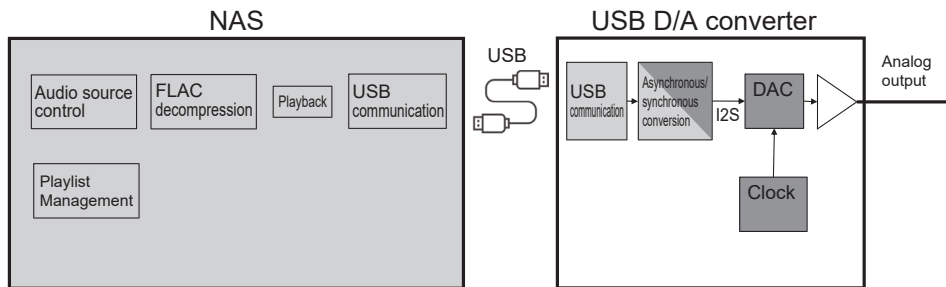

### LAN D/A Converter (diretta) Operation

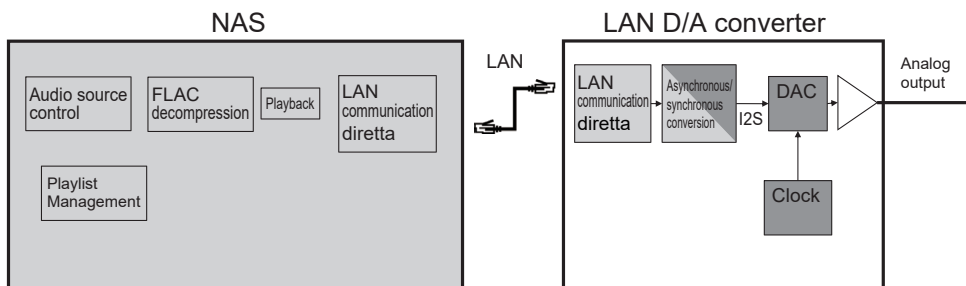

ZERO LINK not only transmits master clock or I2S signals but also performs communications. In other words, the transport informs the audio source format to the D/A converter before playback, and the DDS of the D/A converter generates a high-quality master clock that synchronizes with this audio format and then transmits it to the transport. The transport generates a pure I2S signal that synchronizes with the master clock and then transmits it to the D/A converter. As a result, the system from the DAC to transport can be fully synchronized with the DAC master clock, completely eliminating the need for asynchronous circuits which decrease the audio quality.

• **Internal operation of ZERO LINK connections**

During the ZERO LINK operation, asynchronous circuit operations can be completely eliminated from the D/A converter.

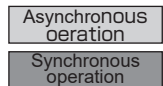

**ZERO LINK Structure (When the Transport is Operated by OpenHome)**

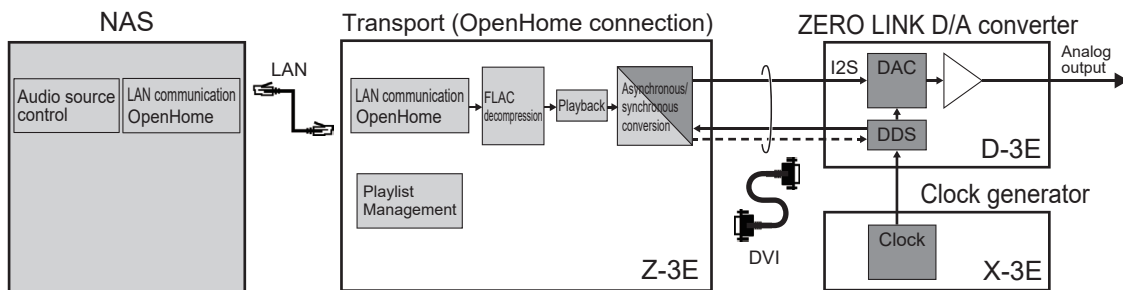

**ZERO LINK Structure (When the Transport is Operated by a USB Connection)**

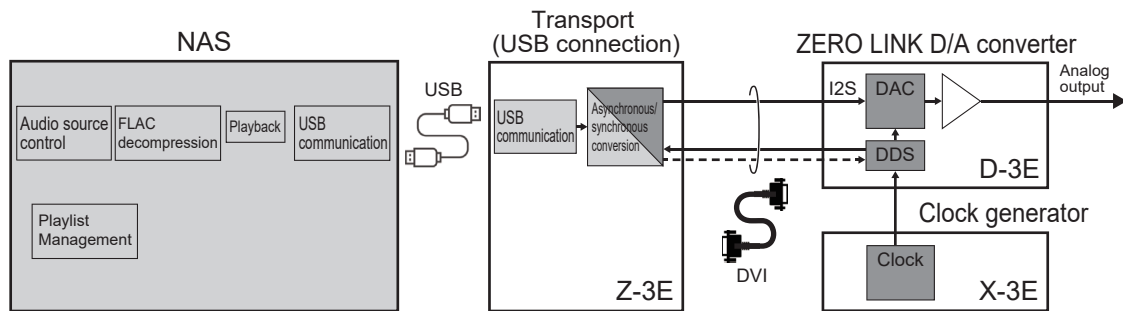

**ZERO LINK Structure (When the Transport is Operated by diretta)**

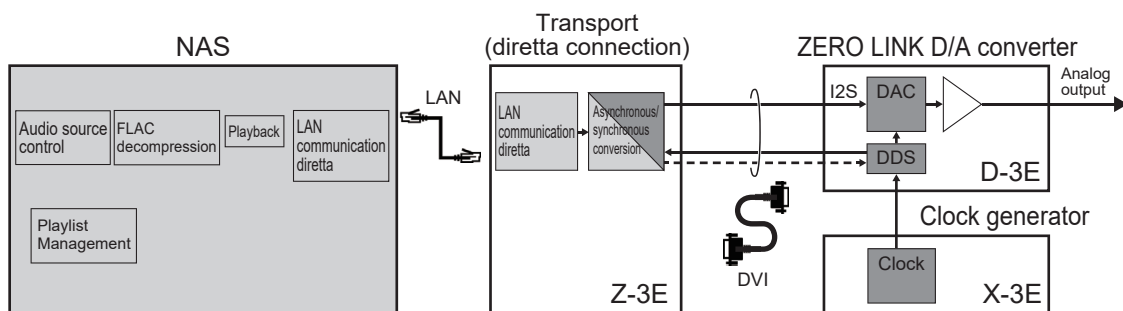

# USB Connection with a Computer

## Windows

To play back DSD/PCM files, install the designated driver to your computer.

### Recommended computer specifications

OS : Windows 7 or later  
CPU : Intel Core 2 processor, 1.6 GHz or higher  
Memory : 1.0 GB or higher

## Mac OS

Operations can be performed with a Mac OS X standard driver.

When using Bulk Pet, install a driver to your computer.

### Recommended computer specifications

OS : Mac OS X 10.8 or later

## When using for the first time (how to install the driver)

1. Access the following website to download the designated driver.  
[http://www.kcsr.co.jp/sn\\_software.html](http://www.kcsr.co.jp/sn_software.html)
2. Without this equipment connected to your computer, start your computer.
3. Before connecting this equipment to the computer, install the designated driver to your computer following the instructions.
4. After the installation completes, restart the computer.
5. After the restart operation completes, connect this equipment to the computer and then turn on the power of this equipment.
6. Operate the input selector of this equipment to select USB.
7. This equipment will be recognized by the computer and driver installation will start automatically.

### Notes:

- Depending on the computer specifications, installation may take some time. Do not turn off both this equipment and the computer until an installation completion message appears.
- Depending on the operating system, certain settings may be required for sound to be output. Configure the settings according to the operating system usage instructions.



## DISPLAY button

The display and indicators other than the power indicator can be turned off by pressing the DISPLAY button on the remote control.

Turning off the display can reduce noise inside the unit thereby improving the audio signal quality.

## Power Cable Connection

When you connect the power cable, be sure to insert the ground-mark side (the side with 2 engraved circles) of the plug into the ground side (the side with a longer insertion hole) of the AC wall outlet (mains). If the plug is connected with the polarity reversed, this product may not be able to deliver its utmost performance.

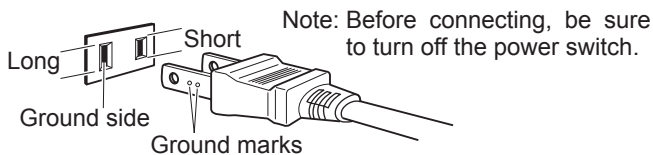

## Balanced Input/Output

The XLR Connector is used for Balanced Input/Output. There are two types of connection, "European Type" and "USA Type".

### 1. European Type (adapter for this unit) (pin 2 = HOT, pin 3 = COLD)

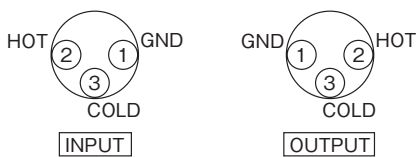

### 2. USA Type (pin 2 = COLD, pin 3 = HOT)

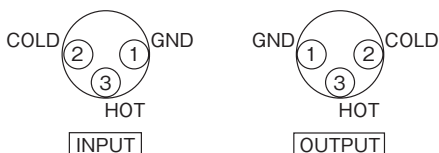

## Attaching the Spike Pins

By replacing the feet with the supplied spike pins, you can tune the audio quality. Point grounding makes the sound focus and auditory lateralization sharper. Furthermore, the audio quality can be subtly tuned by changing the material of the surface on which this equipment is installed.

### Notes:

- When replacing the feet with the spike pins, remove the carbon washers from the feet, and then reattach them to the spike pins.
- When the spike pins are attached, it may be difficult to keep weight balance stable. Take great care not to carelessly apply a force on the corners of the main unit.

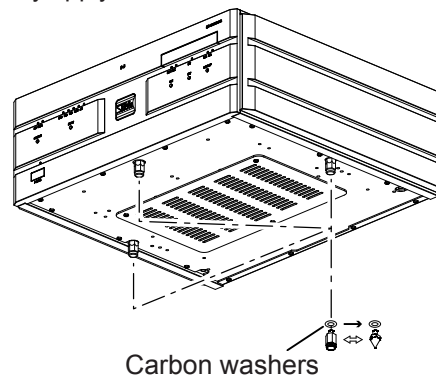

The feet can also be attached to the back-side holes. If the front side of the device is not stable, attach the feet to the back-side holes. (To obtain better audio quality, using the front-side holes is recommended.)

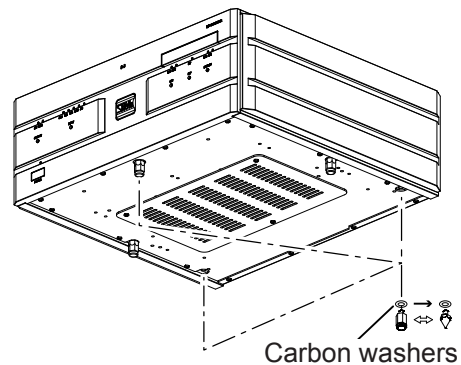

### ⚠ Cautions

- When using the spike pins, be extremely careful not to get injured, etc.
- When using the spike pins, be careful that the surface on which the main unit is installed such as the surface of a table, shelf, etc., may become damaged. Using the spike-receiving board is highly recommended in order to protect the installation surface.

## Protection Pads for Transport

Before use, be sure to remove the pads from the unit. With the pads left attached, you cannot fully enjoy the high audio quality of the unit.

- In order to maintain the audio quality, the top cover and terminals on the rear panel are intentionally not secured.
- If you shake the unit, you will hear a rattling sound. It is not an abnormality.
- When you transport the unit, reattach the pads to the original places.

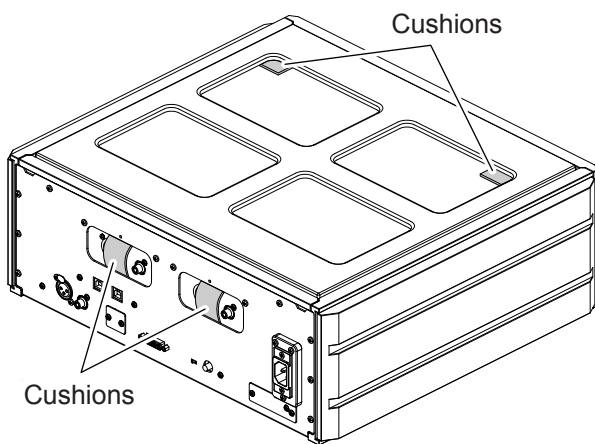

## Maintenance

When the unit has become dirty, wipe it clean using a soft cloth. To remove stubborn stains, dilute some dish-washing liquid in 5 or 6 times as much water, soak a soft cloth in the solution, wring it out well, wipe away the stains, and then wipe the surfaces dry with a dry cloth.

Never use alcohol, paint thinners, benzene, insecticides or other volatile substances since they may mar or remove the surface gloss.

Bear in mind that rubbing surfaces with a chemical cleaning cloth or leaving such a cloth in contact with a surface for an extended time may result in deterioration.

## Troubleshooting

### No sound is output. The unit does not turn on.

- Check that an external clock is connected.
- Check that the power of the external clock is on.
- Check that the screw of the SMA cable is tightened all the way.
- Check the setting of the input selection switch.
- Check the setting of the output selection switch.
- Check that control application NAS and output devices are selected correctly.

If the problem persists even after checking the above items, turn off the all devices such as routers, NAS, and network transport, check the cable connections, and then turn on the power of all the devices again.

## Specifications

Supported sampling frequency (ZERO LINK, USB)	Maximum 768 kHz (PCM)/ Maximum 22.6 MHz (DSD)
Supported sampling frequency (coaxial AES/EBU)	Maximum 192 kHz (PCM)/ Maximum 2.8 MHz (DSD64 DoPv1.1)
PCM quantization bit rate (ZERO LINK, USB)	16 bits, 24 bits, 32 bits
PCM quantization bit rate (coaxial AES/EBU)	16 bits, 24 bits
Digital input	ZERO LINK, USB (Type B)×2, coaxial (S/PDIF), AES/EBU
External clock input	10 MHz (SMA 50 ohms)
Analog output	XLR×1, RCA×1
Analog output level (XLR)	5.6 Vrms
Analog output level (RCA)	2.8 Vrms
Frequency characteristic	2 Hz to 120 kHz (+0/-1dB)
S/N ratio	110dB
Total harmonic distortion	0.008% (NOS/176.4kHz)
Analog filter	Primary passive type
Power voltage	230 V AC, 50 Hz
Power consumption	48 W
Maximum external dimensions	454 mm (W) x 174 mm (H) x 407 mm (D)
Weight	28 kg



**CSR, Inc.**

<https://www.soulnote.link/>